



REDISCOVER FIRE

# CONTENTS

About Us	4-7
Power Vent System	8-11
Technology and Optional Features	14-21
Front Facing	22-35
Corner	36-49
Three Side	50-61
Space Creator	62-77
Tunnel	78-89
Stand Alone	90-101
Traditional	102- 107
Models	108-111
Credits	112



# ABOUT US

**EN** Fireplaces add comfort and warmth to any home. They can also be a striking architectural addition, becoming a focal point of the space.

Ortal, founded in 1986, has gained global recognition for its extensive selection of modern gas fireplaces, produced with close attention to detail, finishing and quality. Our products combine traditional and modern design with technological innovations that make them eco-friendly with high heating efficiency ratings. Stunning fireplaces that are safe, beautiful and very effective is made possible with our proprietary advanced technology, which also allows you to install our fireplaces where others cannot.

Ortal's modern fireplaces are available in an array of sizes to suit various design and architectural needs.

We also welcome your vision for custom-made fireplaces, addressing any special requirements, size and use. Our high quality fireplaces are CSA and CE certified and our dealers are committed to provide you service and installation excellence.

 **GREEN STATEMENT:** Ortal offers a green, environmentally friendly heating solution for the modern era. With Ortal's high efficiency ratings and contemporary designs, you don't have to sacrifice form for function. Ortal's unique design maximizes the fireplace's radiant heat. Additional efficient components include Ortal's use of direct vent technology, electronic ignition (instead of a standing pilot) and low maintenance requirements.



**DE** Kamine geben dem zu Hause Gemütlichkeit und Wärme. Sie können dazu als eindrucksvolle architektonische Ergänzung dienen und zum Mittelpunkt eines Raumes werden.

Ortal wurde im Jahre 1986 gegründet und hat seither globale Anerkennung mit dessen umfangreicher Auswahl an modernen Gaskaminen, die mit hoher Sorgfalt in Sachen Detail, Qualität und Perfektion gefertigt wurden, erlangt. Unsere Produkte verbinden traditionelle und moderne Designs mit technologischen Innovationen, wodurch sie umweltfreundlich sind und eine hohe Heizungseffizienz erreichen. Die Herstellung unserer sicheren, wunderschönen und hocheffektiven Kamine ist durch unsere eigene fortgeschrittene Technik möglich gemacht, die es Ihnen erlaubt unsere Kamine dort einzubauen, wo andere nicht zu platzieren sind.

Ortals umfangreiche Auswahl an modernen Kaminen ist die Größte in Nordamerika und Kamine sind in einem großen Aufgebot an Größen vorhanden, um unterschiedlichsten Designs und architektonischen Bedürfnissen entgegenzukommen.

Wir nehmen außerdem gerne Ihre Ideen für persönlich gestaltete Kamine entgegen, wobei wir auf jegliche besonderen Bedürfnisse, Größen und Sonstiges eingehen. Unsere hochqualitativen Kamine sind CSA und CE Zertifiziert und unsere Händler sind sehr engagiert dabei, ihnen guten Service und vortreffliche Einbauten zu bieten. Ortal Kamine sind in Nordamerika über Ortal USA zugelassene Händler erhältlich.

 **UMWELTAUSSAGE:** Ortal bietet eine grüne, umweltfreundliche Heizlösung für den modernen Mensch. Mit Ortals guten Leistungsbewertungen und zeitgenössischen Designs müssen sie Gestaltung nicht für Leistung opfern. Ortals einzigartige Designs maximieren die Strahlungswärme der Kamine. Zusätzlich sind die Folgenden effizienten Bestandteile enthalten: Ortals Einsatz von Direct-Vent Technologie, elektrische Zündung (anstatt einer Standard-Zündung) und geringer Wartungsaufwand.



**NL** Een open haard geeft elke woning comfort en warmte. Hij kan ook een opvallende architectonische verrijking zijn en een blikvanger worden in de ruimte.

Ortal werd in 1986 opgericht en heeft wereldwijde erkenning gekregen voor zijn uitgebreide aanbod van moderne gasopenhaarden. Onze haarden worden met de grootste aandacht voor de details, de afwerking en de kwaliteit gemaakt. Onze producten combineren traditionele en moderne designs met technologische innovaties die ze milieuvriendelijk maken maar ook een zeer efficiënte verwarming garanderen. Indrukwekkende haarden, veilig, mooi en buitengewoon effectief dankzij onze eigen geavanceerde technologie, die u ook de mogelijkheid geeft om onze producten te installeren op plaatsen waar andere open haarden uitgesloten zijn.

De uitgebreide selectie open haarden van Ortal, een van de grootste van Noord-Amerika, is verkrijgbaar in een waaier van formaten die op uiteenlopende design- en architectonische behoeften antwoorden.

Wij maken ook open haarden op maat voor alle bijzondere behoeften in termen van afmetingen en toepassingen. Onze kwaliteitsvolle open haarden bezitten de CSA- en CE-certificering en onze dealers leveren u een uitstekende service en installatiediensten. De open haarden van Ortal zijn in Noord-Amerika verkrijgbaar via door Ortal USA erkende dealers.

 **GROENE VERKLARING:** Ortal presenteert een groene, milieuvriendelijke oplossing voor de moderne tijd. Dankzij de hoogefficiënte prestaties en de eigentijdse designs van Ortal hoeft u de vorm niet op te offeren aan de functie. Het unieke design van Ortal maximaliseert de stralingswarmte van de haard. Andere efficiënte componenten zijn de directe ventilatietechnologie van Ortal, de elektronische ontsteking (in plaats van een waakvlam) en de beperkte onderhoudseisen.



**ES** Las chimeneas añaden confort y calidez a cualquier hogar. También pueden ser una sorprendente adición, convirtiéndose en un punto focal del espacio.

Ortal, fundada en 1986, ha ganado reconocimiento mundial por su extensa selección de modernas chimeneas a gas, producidas con gran atención al detalle, acabado y calidad. Nuestros productos combinan el diseño tradicional y moderno con innovaciones tecnológicas que los hacen amigables al ambiente con altas calificaciones de eficiencia de calefacción. Sorprendentes chimeneas que son seguras, hermosas y muy efectivas son hechas posibles con nuestra tecnología avanzada exclusiva, la cual también le permite instalar nuestras chimeneas donde otros no pueden.

La extensa selección de chimeneas modernas de Ortal es la más grande en Norteamérica y están disponibles en variedad de tamaños para adaptarse a diversas necesidades arquitectónicas y de diseño.

También damos la bienvenida a su visión para chimeneas a la medida, tratando cualquier requerimiento, tamaño y uso especiales. Nuestras chimeneas de alta calidad están certificadas CSA y CE, y nuestros vendedores están comprometidos a proporcionarle excelencia de servicio e instalación. Las chimeneas Ortal están disponibles en Norteamérica a través de vendedores aprobados por Ortal USA.

 **DECLARACIÓN VERDE:** Ortal ofrece una solución de calefacción verde y amigable al ambiente para la era moderna. Con las altas calificaciones de eficiencia de Ortal y sus diseños contemporáneos, usted no tiene que sacrificar forma por función. El diseño único de Ortal maximiza el calor radiante de la chimenea. Componentes eficientes adicionales incluyen el uso por Ortal de tecnología de ventilación directa (en lugar de un piloto) y bajos requerimientos de mantenimiento.



# WHY ORTAL?

## DESIGN



**CIRCLE**  
10-15



**INTERIOR DESIGN**  
94-95

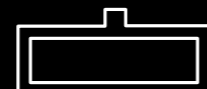

**WIDE FRAME**  
100-101



**ISLAND**  
16-21



**"OPEN" FIRES**  
94-95



**OVER 70  
MODELS**



**LIGHTING**  
104-105

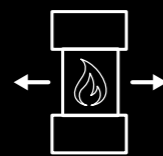

**INDOOR  
OUTDOOR**  
16-21



**EXTRA  
TRANSPARENT  
GLASS**

## TECHNOLOGY



**FAN EXHAUST  
SYSTEM**  
98-99



**HEAT BARRIER**  
106-107



**SMART HOME  
& APPS**  
110



**BLOWER**  
102-103



**DUAL LINE  
BURNER**  
111



**LARGE  
FIREPLACES AS  
STANDARD**  
110

# ISLAND & CIRCLE

**EN** From every angle, this Fireplace provide warmth and views. With the flexibility to place it anywhere in the room from center to side, it's a real design feature. Also available in two-thirds circular design when the perfect place for it is against the wall.

Island 130





Island 80



Island 80



Circle 70

\*Color and size options are available for the hood and base. Please contact Ortal for more information . Each order will require Ortal's order confirmation.

\*\* Joint venture JC BORDELET



Island 80



Circle 270



Circle 70





Circle 270

Circle 70  
(270°)

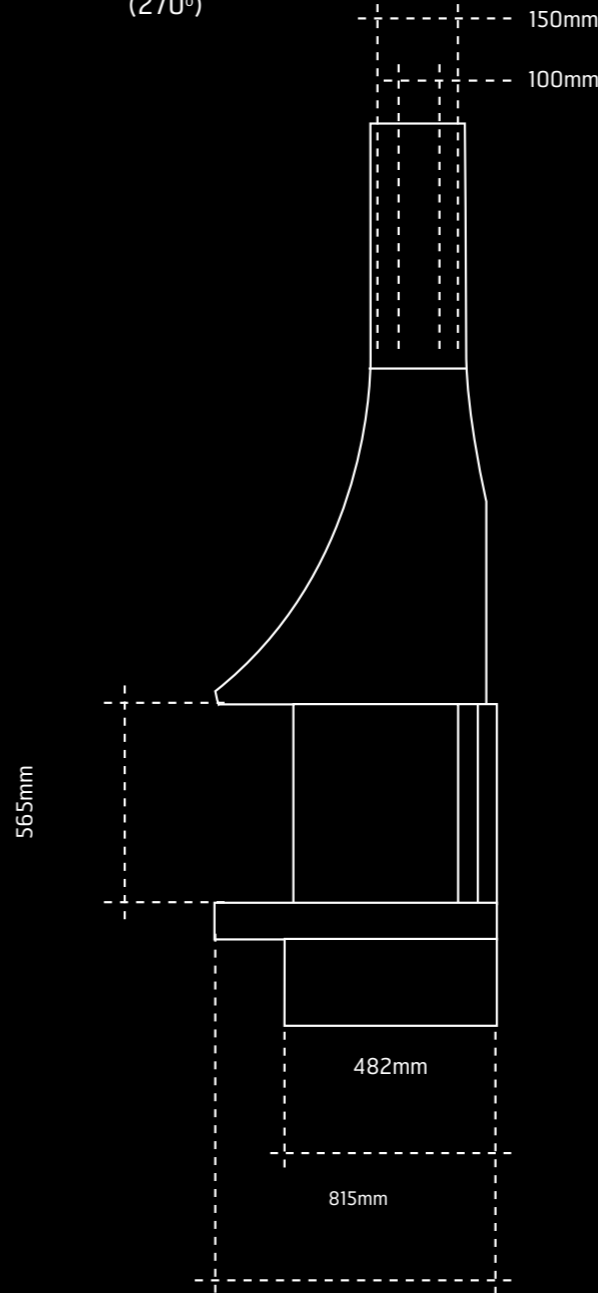

Circle 70

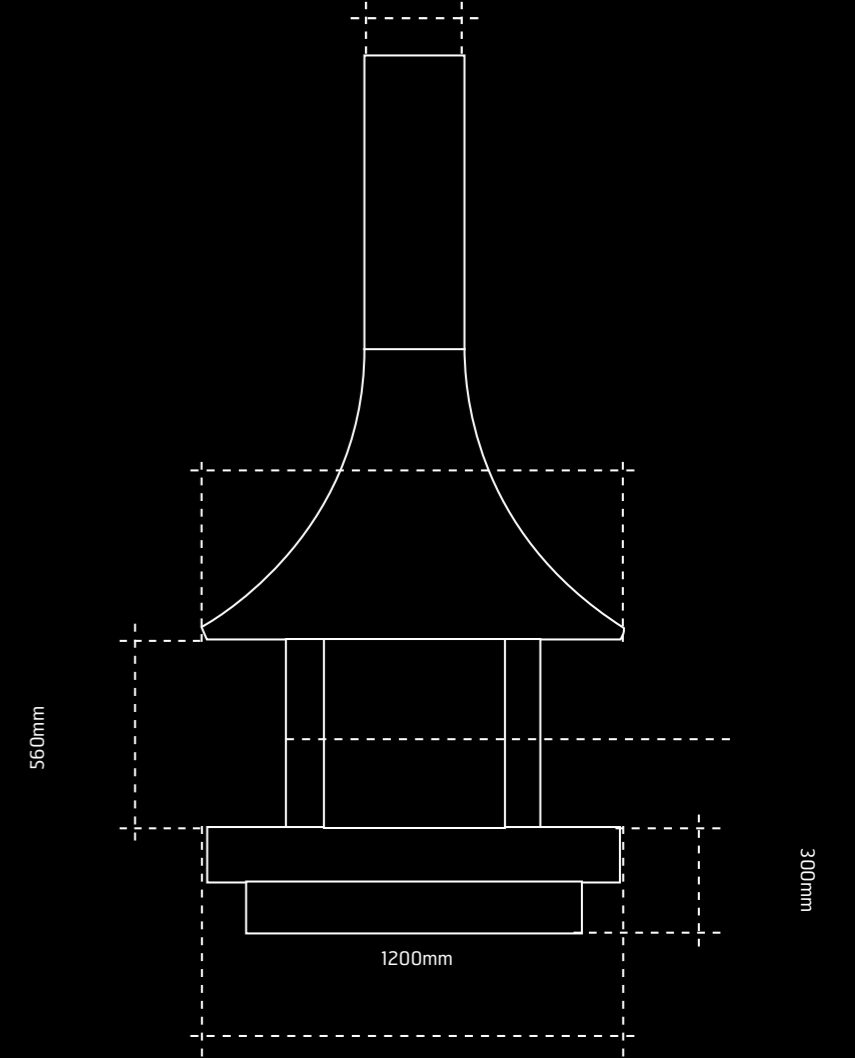



Circle 70

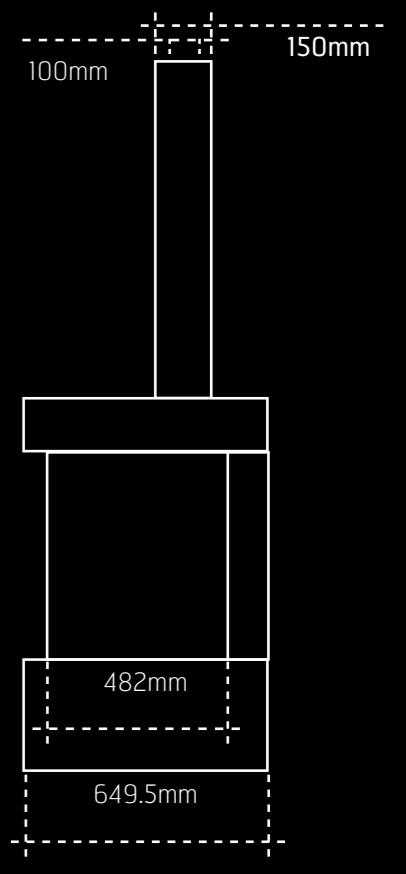
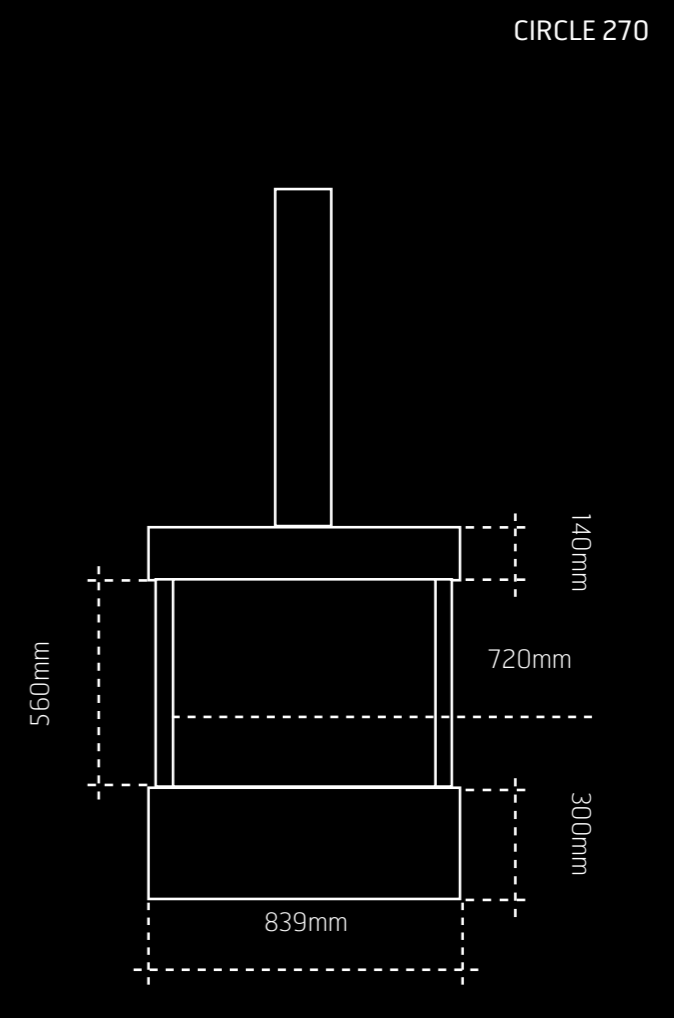
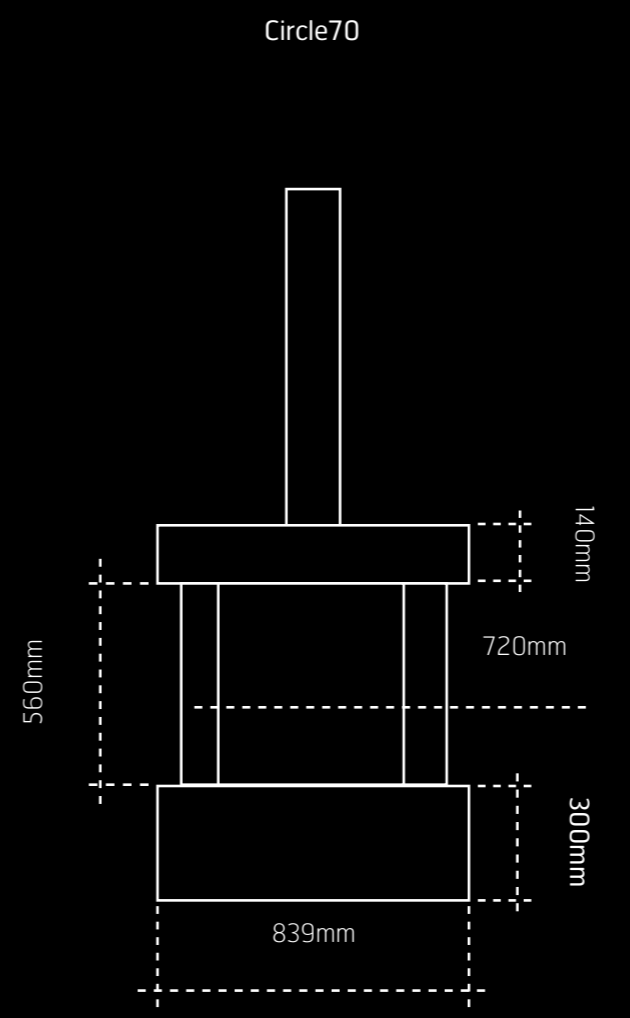

# FRONT FACING

- EN** Our front-facing fireplaces can be beautifully integrated into walls and architectural elements.
- DE** Unsere nach vorne gerichteten Kamine können auf wunderbare Art in Wände und architektonische Elemente integriert werden.
- NL** Onze frontale haarden kunnen prachtig worden opgenomen in wanden en architectonische elementen.
- ES** Nuestras chimeneas vista al frente pueden ser bellamente integradas en paredes y elementos arquitectónicos.

Clear 40H70



Modern frameless gas fireplaces with Ortal's leading innovative technology



Clear 170



Clear 110



clear 110H



Architect &  
designer favorites

Clear 200



Minimal 130

Clear 75X65  
Double breaks



# FRONT FACING

Model	D	A	K	B	E	C/F	J	H	I	G
Clear 40	521	428	260	550	846	383	233	100	147	210
Clear 40H70	524	428	262	700	996	383	227	100	147	210
Clear 40H90	522	424	261	900	1196	383	233	100	147	210
Clear 60x80	644	552	322	740	1030	380	234	100	147	210
Clear 75x65	872	778	436	650	927	380	234	100	147	210
Clear 75	856	740	428	440	721	377	211	100	147	210
Clear 75ST	907	745	454	433	652	397	216	100	147	--
Clear 110	1216	1100	608	350	651	377	211	130	202	210
Clear 110H	1216	1108	608	550	851	380	214	130	202	210
Clear 110ST	1273	1105	636.5	346	567	397	216	130	202	--
Clear 130	1386	1278	693	350	651	377	211	130	202	210
Clear 150	1636	1527	818	350	651	380	214	130	202	210
Clear 150H	1636	1528	818	550	851	380	214	130	202	210
Clear 150ST	1693	1525	846.5	346	568	397	216	130	202	--
Clear 170	1836	1728	918	350	651	380	214	130	202	210
Clear 200	2076	1968	1038	350	651	380	214	130	202	210
Clear 200H	2076	1968	1038	550	851	380	214	130	202	210
Clear 250	2502	2444	1251	400	702	444	284	130	202	210

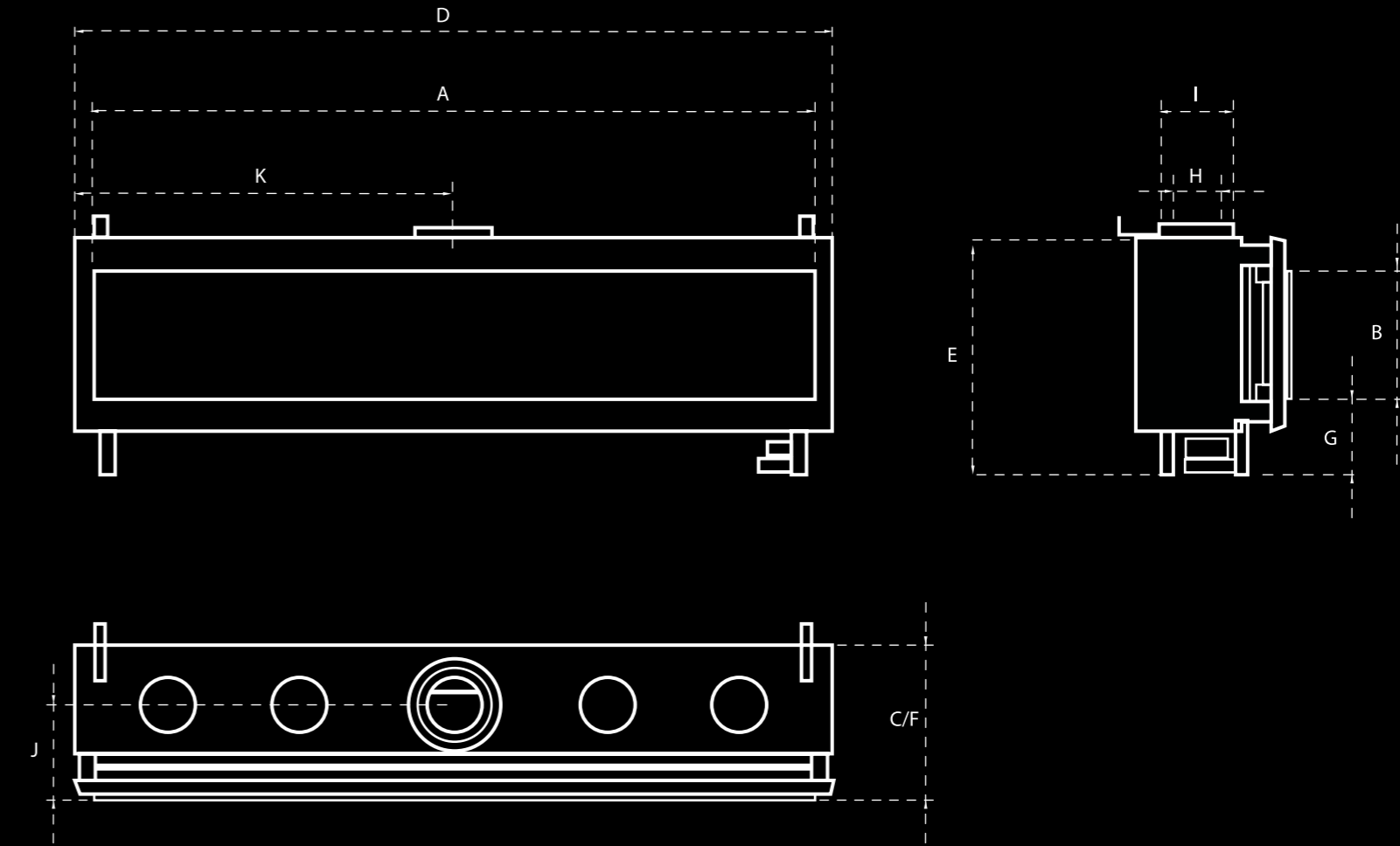



# MINIMAL LINE

MM

Model	A	B	C	D	E	F	H	I	J	K
Minimal 110	898	804	982	1036.3	962.7	682	132	198	458.5	517.5
Minimal 130	1083	867.5	682	1221.74	1013.5	682	132	198	458.5	613.6

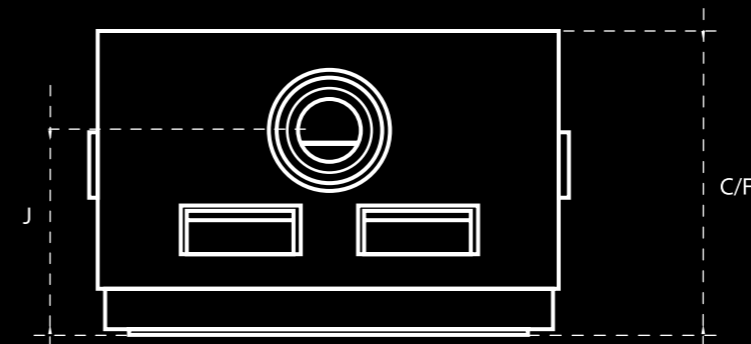
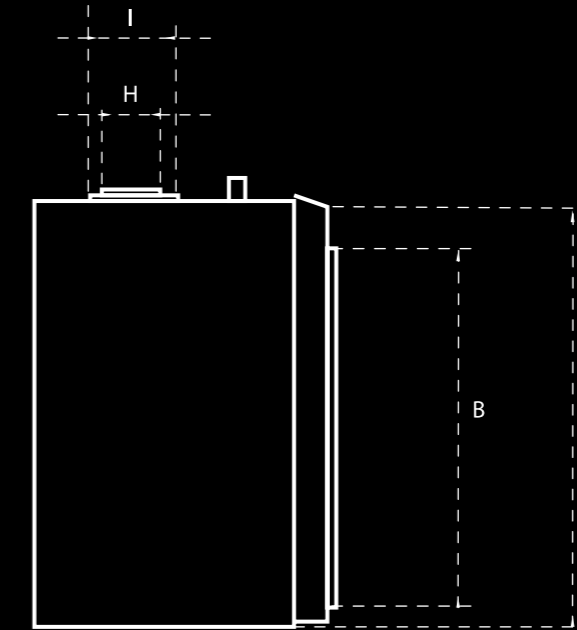
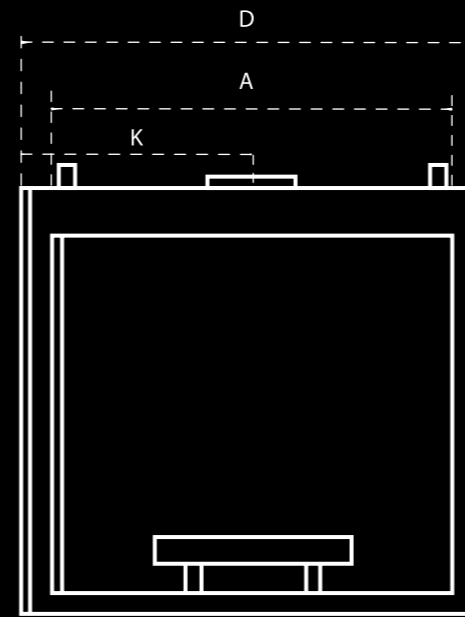

# CORNER

- EN** Wide or narrow, cozy or imposing, corner fireplaces are an ideal and flexible architectural solution.
- DE** Ob breit oder schmal, gemütlich oder imposant, Kaminecken sind eine ideale und flexible architektonische Lösung.
- NL** Breed of smal, knus of imposant: onze hoekhaarden zijn een ideale en flexibele architectonische oplossing.
- ES** Anchas o estrechas, íntimas o imponentes, las chimeneas de esquina son una solución arquitectónica ideal y flexible.

Clear 75LS  
Double Glass





Clear 110 RS & Clear 110 LS  
Double Glass



Our unique design allows  
for an endless variety of  
finish surfaces.

Clear 150 RS



Clean lines and seamless designs available in over 70 models



Clear 200 RS

Clear 130RS



Clear 150LS

Clear 150LS

# CORNER RS/LS

Model	D	A	K	B	E	F	J	C	H	I	G
Clear 40 RS/LS	524	458	256	550	850	385	305	234	100	147	210
Clear 40H70 RS/LS	517	458	256	700	1000	385	306	228	100	147	210
Clear 40H90 RS/LS	516	468	256	900	1200	385	305	234	100	147	210
Clear 75 RS/LS	777	748	401	480	762	432	373	272	100	147	210
Clear 110 RS/LS	1167	1138	596	400	702	444	375	284	130	202	210
Clear 130 RS/LS	1337	1308	681	400	702	444	375	284	130	202	210
Clear 150 RS/LS	1587	1558	806	400	702	444	375	284	130	202	210
Clear 170 RS/LS	1787	1758	906	400	702	444	375	284	130	202	210
Clear 200 RS/LS	2027	1998	1026	400	702	444	375	284	130	202	210

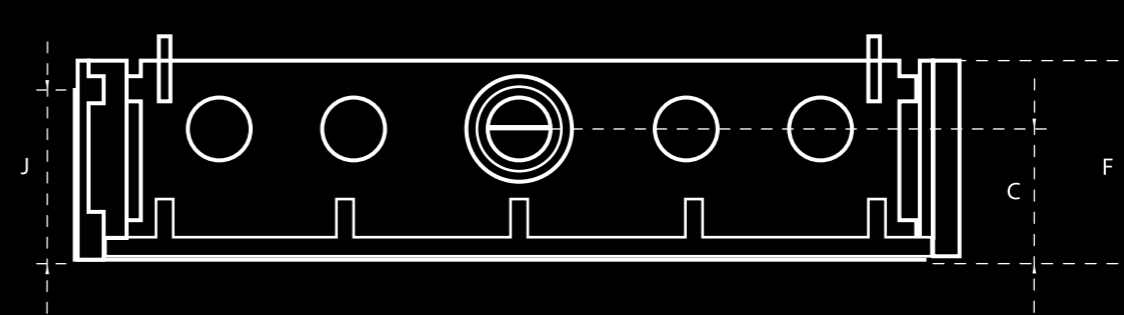
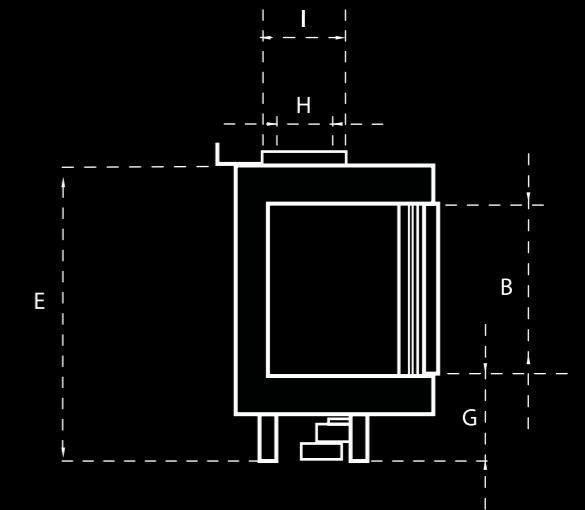
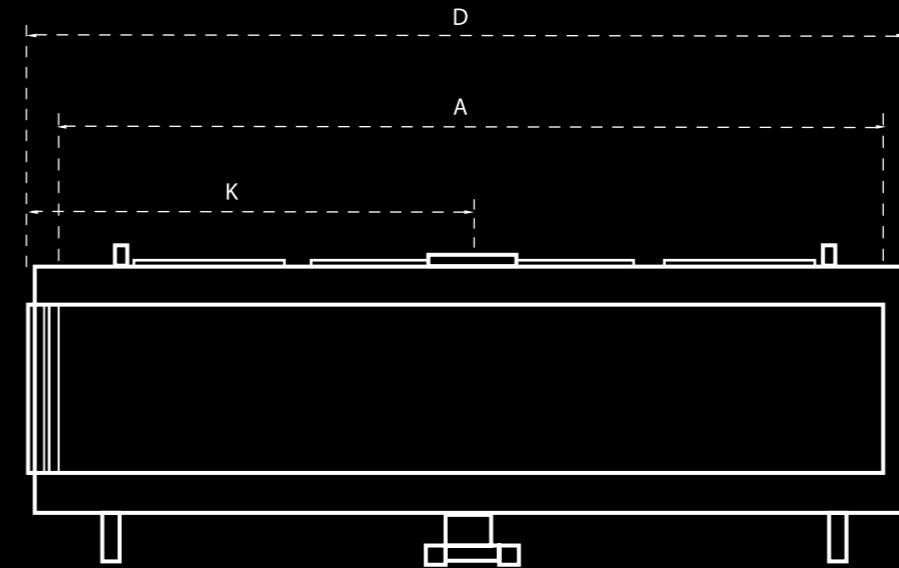

# THREE SIDE

- EN** Big or small, our built-in, three-sided fireplaces are architecturally stunning elements that can be enjoyed from different angles and spaces.
- DE** Ob groß oder klein, unsere eingebauten dreiseitigen Kamine sind architektonisch umwerfend, da die verschiedenen Elemente von verschiedenen Winkeln und Räumen bewundert werden können.
- NL** Groot of klein, onze ingebouwde driezijdige haarden zijn architectonisch verbluffende elementen, even mooi uit elke invalshoek en in elke ruimte.
- ES** Grandes o pequeñas, nuestras chimeneas de tres lados son elementos arquitectónicamente sorprendentes que pueden ser disfrutados desde diferentes ángulos y espacios.

Clear 170TS



Giving you design freedom and flexibility.



Clear 150 TS



Clear 170 TS





Clear 130 TS



Enhancing the ambience from every side.

clear 75TS H

# THREE SIDE



Model	A/D	K	B	E	F	C	J	H	I	G
Clear 40 TS	512	256	550	850	385	305	234	100	147	210
Clear 40 TS SA	482	241	543	837	372	288	219	100	147	--
Clear 40H70 TS	512	256	700	1000	385	305	228	100	147	210
Clear 40H90 TS	512	256	900	1200	385	305	234	100	147	210
Clear 75 TS	802	401	480	762	432	373	272	100	147	210
Clear TS SA 75	772	386	470	734	438	356	257	100	147	--
Clear 110 TS	1192	596	400	703	702	375	284	130	202	210
Clear 130 TS	1362	681	400	703	702	375	284	130	202	210
Clear 150 TS	1612	806	400	703	702	375	284	130	202	210
Clear 170 TS	1812	906	400	703	702	375	284	130	202	210
Clear 200 TS	2052	1026	400	703	702	375	284	130	202	210
Clear 250 TS	2552	1276	400	703	702	375	284	130	202	210

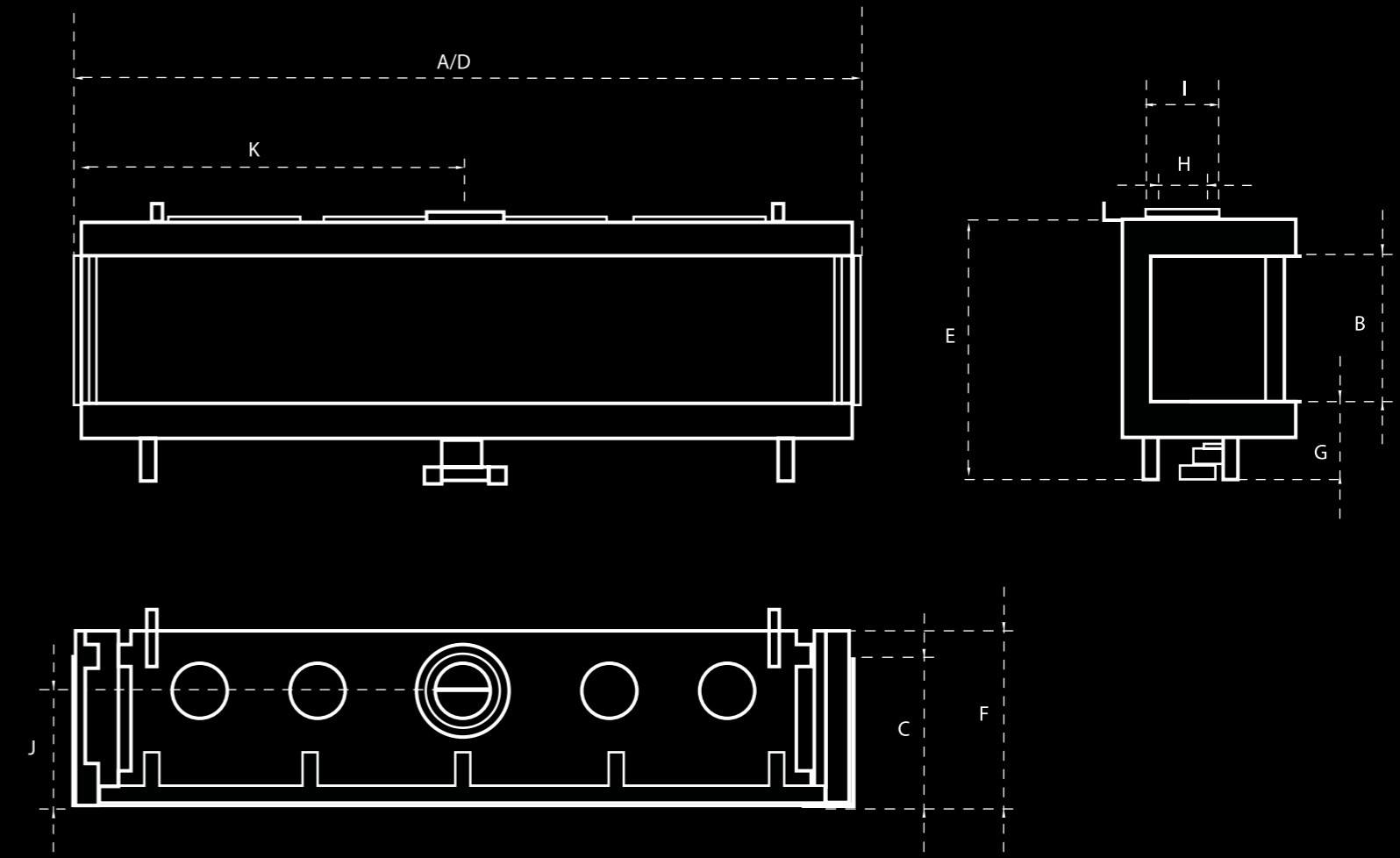

# SPACE CREATOR

- EN** Ortal's Space Creator is a unique way to separate living spaces, yet combine them visually.
- DE** Ortals Space-Creator ist eine besondere Art und Weise Wohnflächen aufzuteilen und sie gleichzeitig visuell zu verbinden.
- NL** De Space Creator van Ortal is een unieke manier om woonruimten te scheiden en toch een visuele band te scheppen.
- ES** Space Creator de Ortal es una forma única de separar espacios de vida, pero combinarlos visualmente.

Space Creator 200





Ortal fireplaces provide flexibility that gives complete design freedom for your fireplace and the space surrounding it.

Space creator 120

A view that's captivating from any angle.



Space Creator 150



Space Creator 120

# SPACE CREATOR

ww	D	A	J	B	E	C\F	K	H	I	L	G
Space Creator 75	868	759	219	424	738	438	166	107	164	--	210
Space Creator 120	1356	1255	219	424	1078	438	163	132	197	714	210
Space Creator 120 mini	1356	1255	219	424	1078	438	163	132	197	714	210
Space Creator 120 midi	1356	1255	219	424	1078	438	163	132	197	714	210
Space Creator 150	1662	1556	219	424	1078	438	163	132	197	714	210
Space Creator 200	2101	1996	219	424	1078	438	163	132	197	714	210

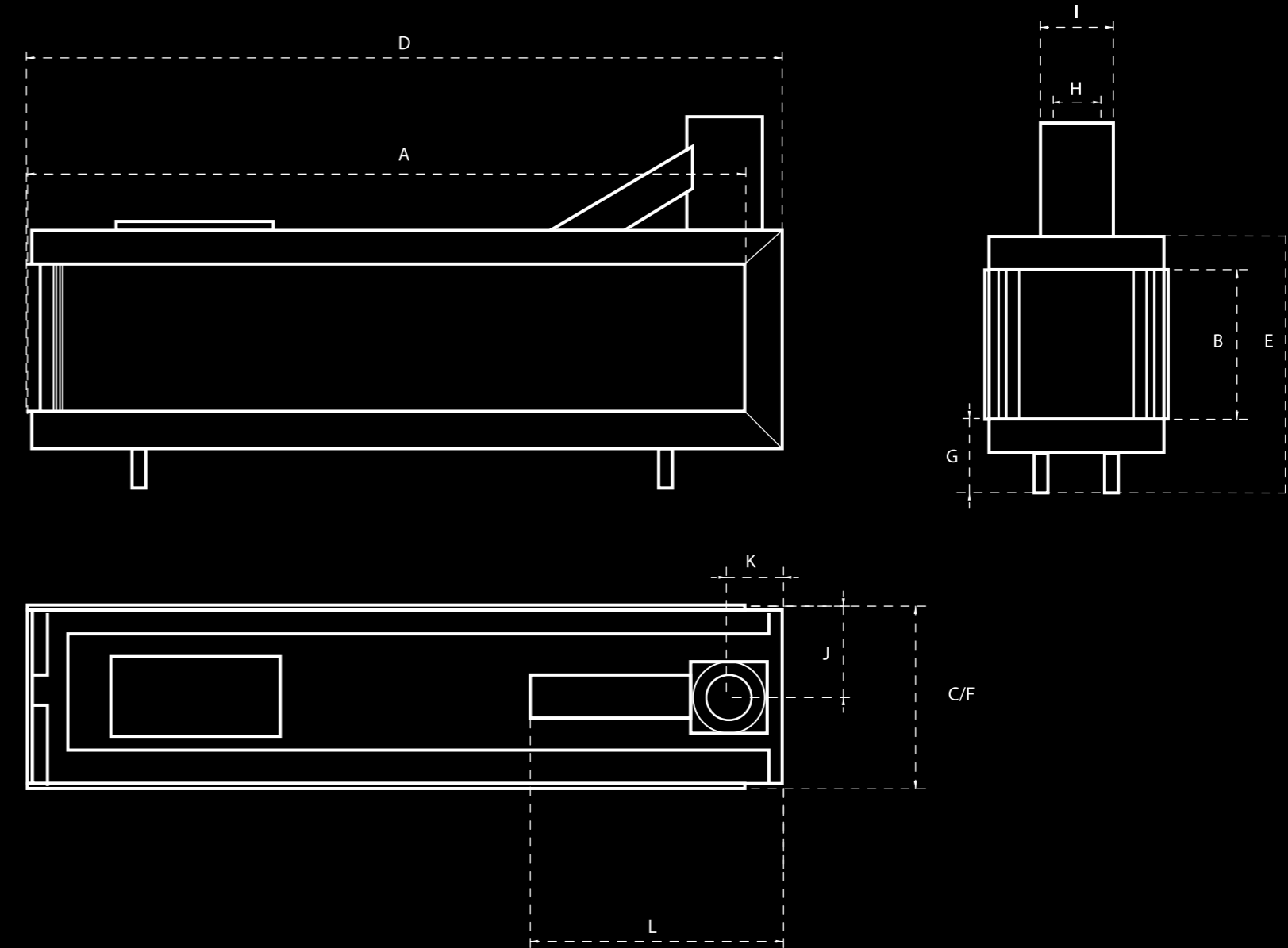

# TUNNEL

**EN** Tunnel fireplaces are visible from both sides while encased in walls or columns. They can be used to divide a living space or to enjoy the warmth and beauty of the flames in two separate rooms. This style can also be used as an indoor/outdoor fireplace.

**DE** Tunnel Kamine sind von beiden Seiten sichtbar und in von Wänden oder Säulen eingeschlossen. Sie sind dabei nützlich, einen Wohnraum aufzuspalten oder die Wärme und Schönheit der Flammen in zwei separaten Räumen zu genießen. Dieser Stil kann außerdem für einen Innen-/Außenkamin benutzt werden.

Clear 130 Tunnel





Clear 110H Tunnel

**NL** Tunnelhaarden worden in wanden of kolommen ingebouwd en zijn aan beide zijden zichtbaar. Ze kunnen worden gebruikt om een woonruimte te verdelen en in de twee afzonderlijke kamers van de warmte en de schoonheid van de vlammen te genieten. Ze kunnen ook worden gebruikt als haard voor binnen en voor buiten.

**ES** Las chimeneas de túnel son visibles desde ambos lados a la vez que están encerradas en paredes o columnas. Pueden ser usadas para dividir un espacio de vida o para disfrutar la calidez y belleza de las llamas en dos habitaciones separadas. Este estilo puede también utilizarse como chimenea de interiores/exteriores.

Clear 150 Tunnel





# TUNNEL



Model	D	A	K	B	E	C/F	J	H	I	G
Clear TU 40	521	428	260	550	845	430	215	107	164	210
Clear 40H70 TU	524	428	262	700	995	430	215	107	164	210
Clear 40H90 TU	524	428	262	900	1195	430	215	107	164	210
Clear 60x80 TU	644	552	322	740	1032	430	215	107	164	210
Clear 65x75	872	778	436	650	930	430	215	107	164	210
Clear TU 110	1216	1108	608	350	650	432	216	132	197	210
Clear 110H TU	1216	1108	608	550	850	432	216	132	197	210
Clear TU 130	1386	1278	693	350	650	432	216	132	197	210
Clear TU 150	1636	1528	818	350	650	432	216	132	197	210
Clear 150H TU	1636	1528	818	550	850	432	216	132	197	210
Clear TU 170	1836	1728	918	350	650	432	216	132	197	210
Clear TU 200	2076	1968	1038	350	650	432	216	132	197	210
Clear 200H TU	2076	1968	1038	550	850	432	216	132	197	210

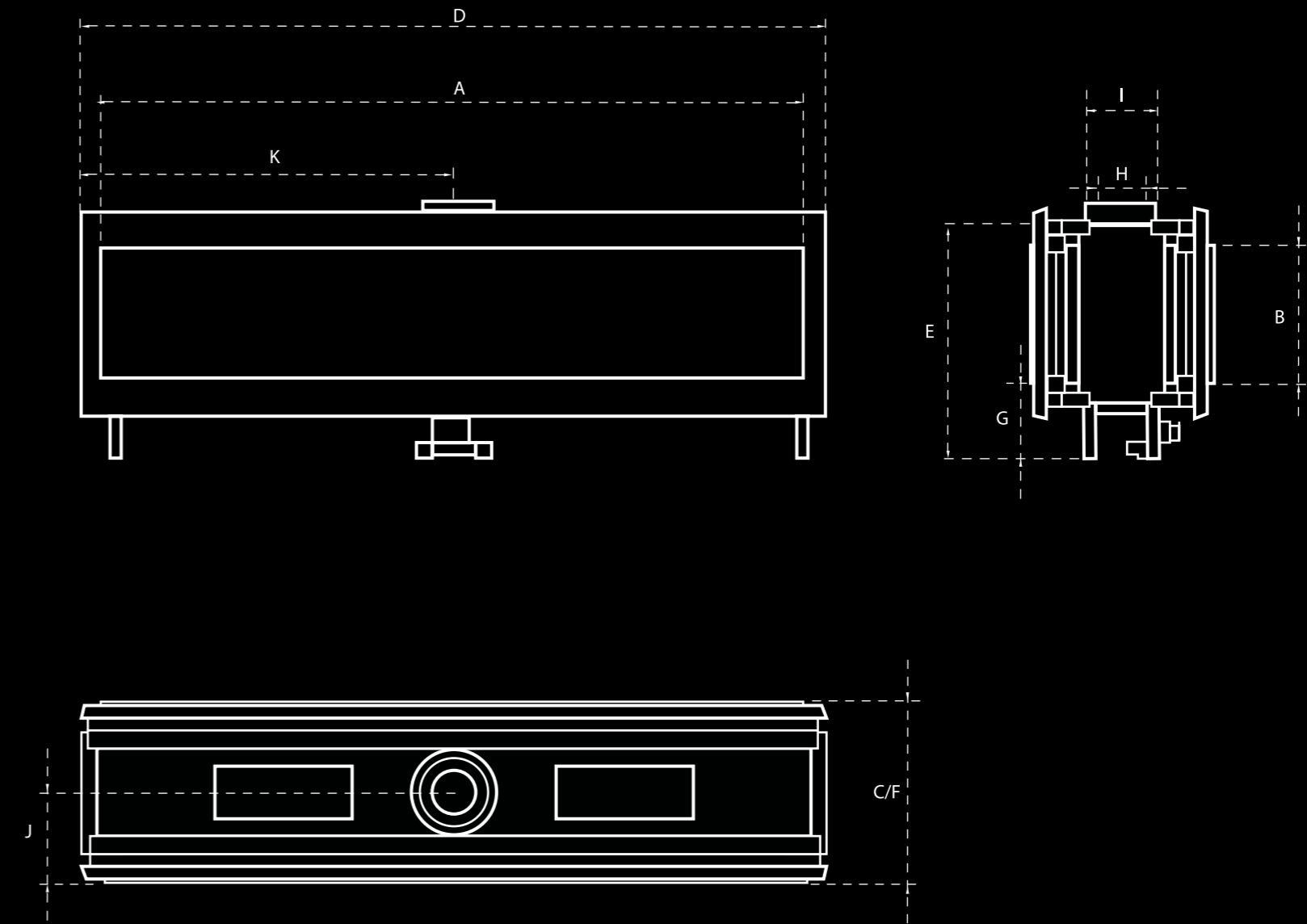

# INDOOR/OUTDOOR FIRES

**EN** When placed in an exterior facing wall, this tunnel fireplace can also be used as an indoor/outdoor fireplace doubling its functionality and extending its impact. Get warmth and ambience inside and outside at the same time. Available as standard for clear130 and clear200.

Tunnel 7.5 m Double Glass indoor/outdoor

INSIDE





Tunnel 7.5 m Double Glass  
indoor/outdoor

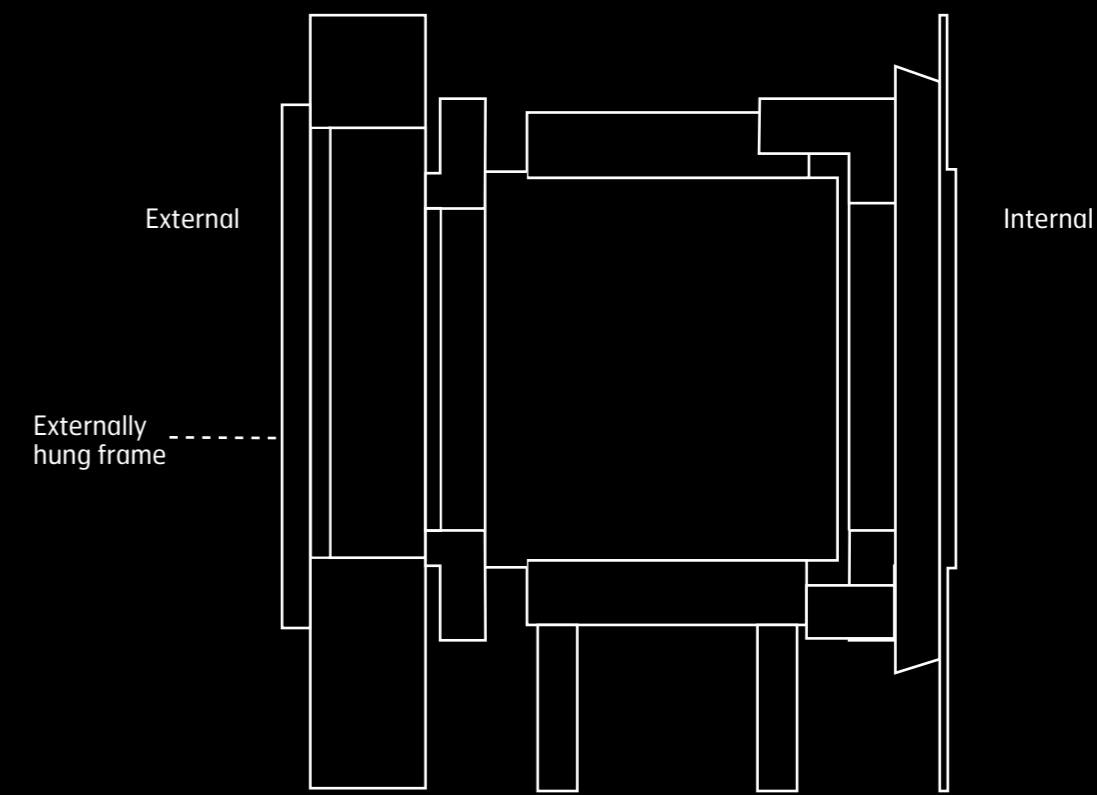

# STAND ALONE

**EN** Sometimes the best placement for a fireplace is as an individual artistic element within a living space. Ortal has an impressive variety of Stand Alone fireplaces which are ideal for remodels as they add minimum disruption.

**DE** Manchmal ist die beste Stelle für einen Kamin ein individuelles künstlerisches Element innerhalb eines Wohnraums. Ortal hat eine beeindruckende Vielfalt an alleinstehenden Kaminen, die Ideal für Umgestaltungen sind, da sie minimale Unterbrechungen verursachen.

Classic F80



Stand Alone 150  
Front

**NL** Soms komt een open haard het mooist tot zijn recht als een individueel artistiek element in een woonruimte. Ortal heeft een indrukwekkende variëteit van vrijstaande haarden. Omdat ze weinig aanpassingen vereisen, zijn ze ideaal voor verbouwingen.

**ES** A veces el mejor lugar para una chimenea es un elemento artístico individual dentro de un espacio de vida. Ortal tiene una impresionante variedad de chimeneas Autónomas que son ideales para remodelar pues añaden una perturbación mínima.





Stand alone 40TS

Stand Alone 75TS





Special design, custom made,  
75 TS,

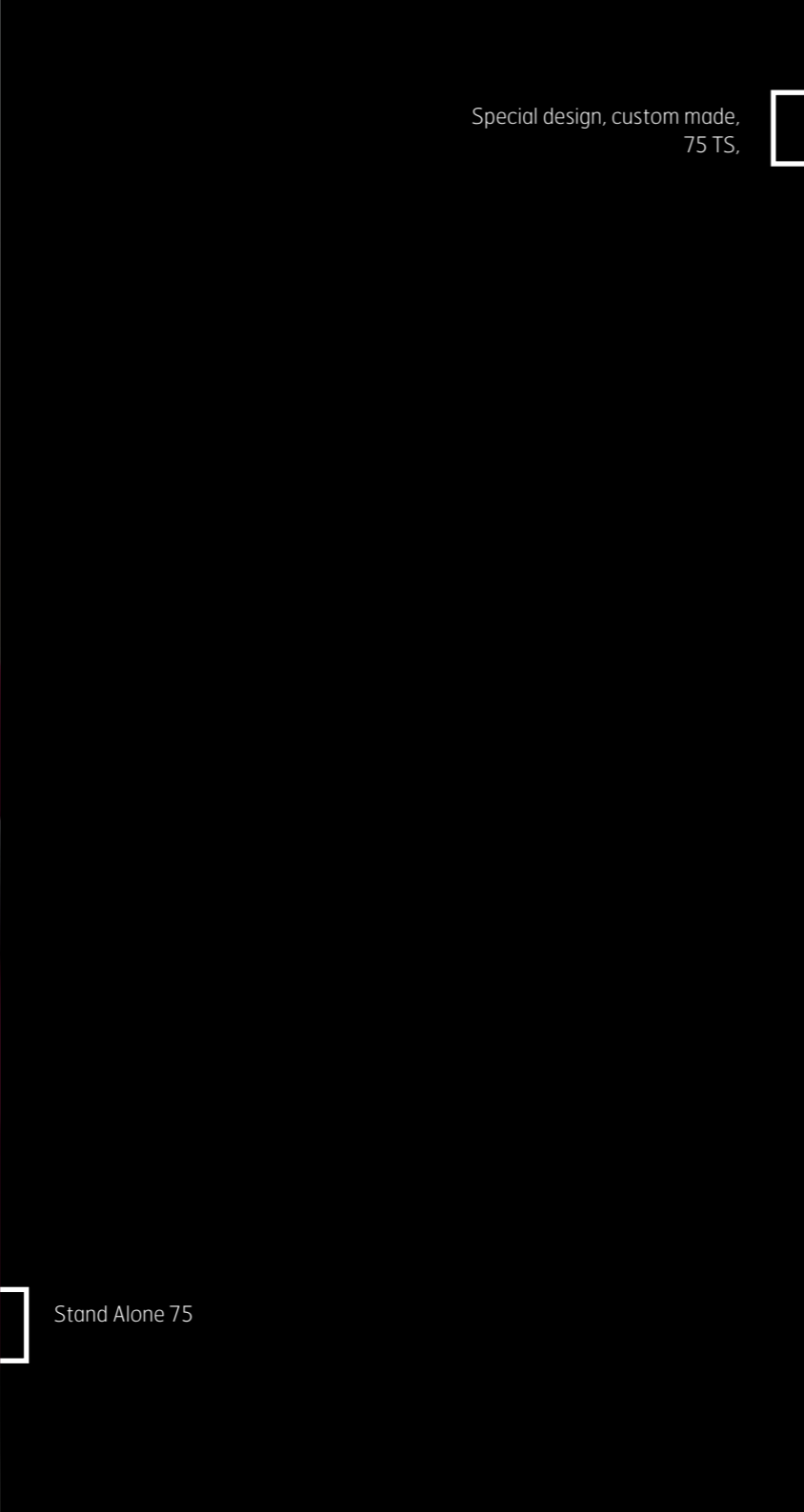

Stand Alone 75



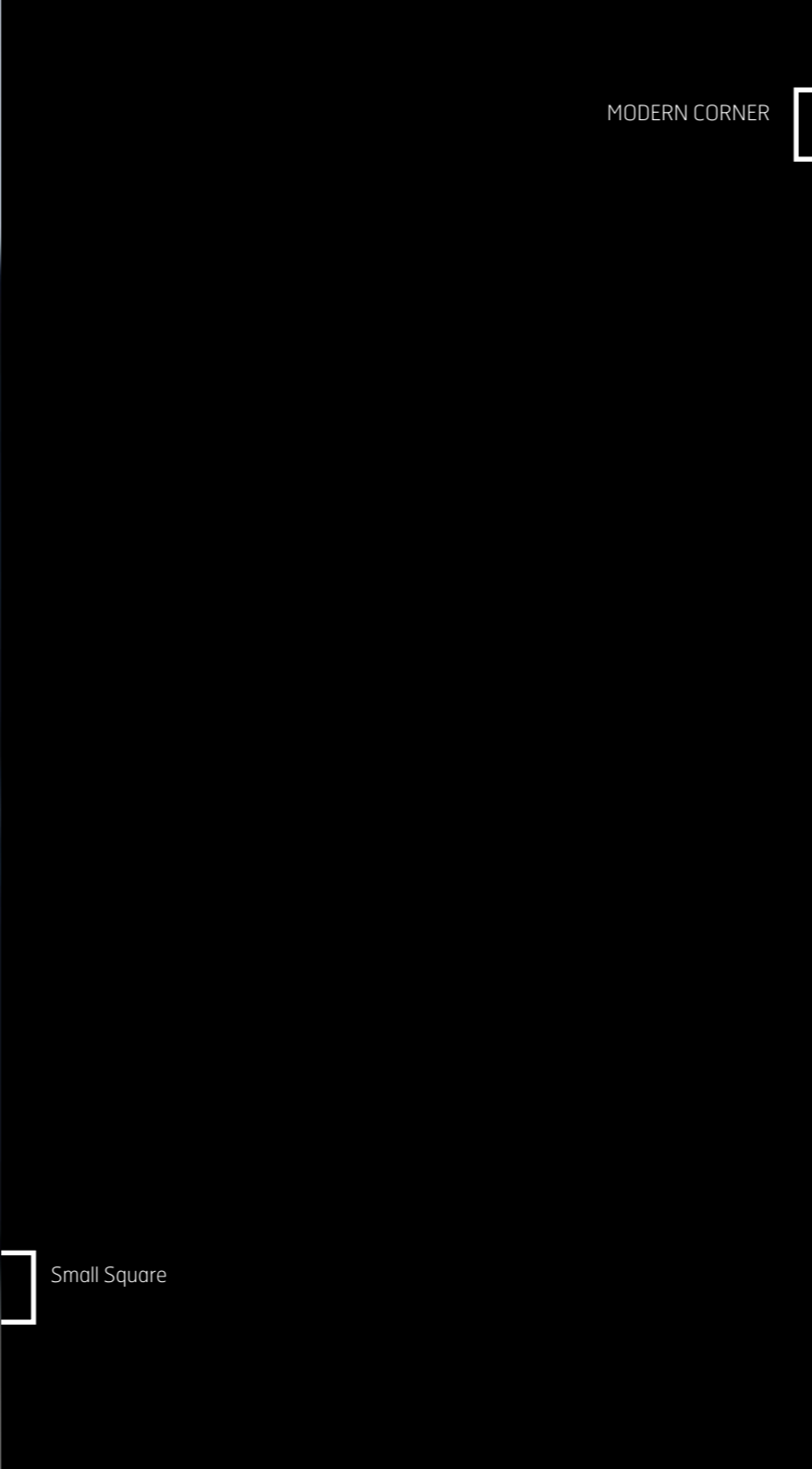

MODERN CORNER

Small Square





OVAL 60/80



Circle 70  
with arc



Classic Corner



Stand Alone 110 Front

**EN** Great design comes in all sizes. The Modern Classic gives you clean lines, which are brilliantly highlighted by its colored glass exterior. Choose from black, white or red for a subtle, stunning feature fireplace.

Classic Modern



Color Options:



# CUSTOM FIRES

**EN** Ortal custom fires fit wherever your imagination and inspiration take you, in additional sizes, uses and styles.

Space Creator 150H



Space Creator 200



# VARIETY OF INTERIOR DESIGN MEDIA

**EN** Fireplaces can be delivered with a choice of media: Log Set, Branch Set, Ceramic stones and glass in a variety of color options. Other media approved for use in these appliances can be substituted after market. Please visit our website to view our range of state-of-the-art media and logs.

**DE** Kamine können mit einer Auswahl an Medien geliefert werden: Rundholz-Set, Ast-Set, Keramiksteine und Glass in verschiedenen Farbvarianten. Andere Medien, die für den Gebrauch an diesen Einrichtungen zugelassen sind, können im Sekundärmarkt substituiert werden. Bitte besuchen Sie unsere Webseite, um einen Einblick in unser Sortiment an modernsten Medien und Rundhölzern zu erhalten.

**NL** De haarden zijn leverbaar met uiteenlopende aankledingen: houtblokken, takken, keramische stenen en glas in diverse kleuren. Andere voor gebruik met deze toestellen goedgekeurde aankledingen kunnen achteraf worden geïnstalleerd. Bezoek onze website voor onze geavanceerde aankledingen en blokken.

**ES** Las chimeneas se pueden entregar con una variedad de medios: Juego de Troncos, Juego de Ramas, Piedras cerámicas y vidrio en varias opciones de color. Otros medios aprobados para uso en estos aparatos pueden ser sustituidos luego de la compra. Visite nuestro sitio web para ver nuestra gama de modernos medios y troncos.



Reflective Interior



Chatsworth – Tan Herringbone Bond



Jamestown – Burgundy Herringbone Bond



Concrete beam



Black Beam



Fire Glass 20# Clear (1kg/bag)  
Cat. # MLCC



Fire Glass 20# Orange (1kg/bag)  
Cat. # MLCO



Fire Glass 20# Black (1kg/bag)  
Cat. # MLCB



Fire Glass 20# Blue (1kg/bag)  
Cat. # MLCL



White Pebbles – little stones (50pcs/Set)  
Cat. # MLSTW



Grey Pebbles – little stones (50pcs/Set)  
Cat. # MLSTG



Grey Pebbles Big Stones (24pcs/Set)  
Cat. # MLPBG



White pebbles big stones (24pcs/set)  
Cat. # MLPBW



MLRCL  
Driftwood Ceramic Fiber Logs with Beige Embers



MLLG  
Charred Oak Clay Logs with Black Embers



MLRL  
Split Oak Ceramic Fiber Logs with Black Embers



English logs  
Long - MLENL Short - MLENS

# FAN EXHAUST SYSTEM

**EN** Among the industry's most sophisticated, Ortal's Fan Exhaust System allows you to install our fireplaces in locations that conventional direct vent systems can't.

The placement of the fireplace is no longer dependent upon the venting pathway. This system allows increased flexibility for locating the appliance inside the building.

**DE** Ortal's Lüftersystem mit Kraftantrieb zählen zu den am weitesten fortgeschrittenen der Industrie und erlauben die Installation von Kaminen in Standorten in denen herkömmliche Lüftersysteme nicht anzubringen wären.

Die Platzierung des Kamins ist nichtmehr länger von der Lage der Lüftung abhängig. Dieses System bietet erhöht Flexibilität bei der Standortsuche der Vorrichtung im Gebäude. Das Lüftersystem mit Kraftantrieb erzeugt einen mechanischen Zug an den Auspuff-Verbrennungsgasen wodurch längere vertikale und horizontale Lüftungssysteme ermöglicht werden, die Architekten, Designern und Konstrukteuren die Arbeit erleichtert.

Vorteile des Ortal Lüftersystems mit Kraftantrieb:

- kleines Lüftungsrohr. 12.7cm Durchmesser Kaminrohr (35CVS nach Duravent).
- Rohre bis zu 33.5m sind möglich, abhängig des Kamin-Modells.
- Kann mit bis zu sechs 90 Grad Winkeln im Lüftungslauf angebracht werden.
- Kann unter der Feuerkammer enden, wobei 1.8m Fuß Höhenunterschied von der oberen Seite der Feuerkammer nicht überschritten werden darf.
- Leiser Betrieb.
- Inline Ventilatorsystem mit 90 Grad Biegung.
- Unterputz-Anschlusseinheit Endzeilen Lüftersystem.
- Flexible Anbringung des Lüfterkastens. Das Inline-Lüftungssystem benötigt mindestens einen 6.4m (lineare Lüfter-Länge) Abstand von dem Verbindungspunkt der Feuerkammer und kann bis zu 13.7m von der Feuerkammer entfernt angebracht werden.
- Ein Elektriker wird bei der Installation nicht benötigt.
- Integrierte Steuerung des Lüftungssystems. Dasselbe Gerät kontrolliert sowohl den Feuerkasten und das Lüftungssystem.



**NL** Dankzij het mechanisch ventilatiesysteem van Ortal, een van de meest geavanceerde op de markt, kunt u onze open haarden installeren op plaatsen waar een conventionele haard met directe ventilatie uitgesloten is.

De plaats van de haard is niet langer afhankelijk van het rookkanaal. Dit systeem vergroot de flexibiliteit van de locatie van de haard in het gebouw. Het mechanisch ventilatiesysteem schept een kunstmatige trek, zodat de verbrandingsgassen langere verticale en horizontale routes kunnen volgen en architecten, ontwerpers en bouwers meer mogelijkheden krijgen.

Voordelen van het mechanisch ventilatiesysteem van Ortal:

- Kleine afvoerpijp. Schoorsteenkanaal 5" diameter (35CVS van Duravent).
- Afvoerkanalen tot een lengte van 110' mogelijk, afhankelijk van het model van de haard.
- Kan met maximaal zes ellebogen van 90° in het kanaal worden geïnstalleerd.
- Het rookkanaal kan lager dan de haard uitmonden, met een maximale verticale val van 6' vanaf de bovenzijde van de haard (zie boven).
- Geruisloze werking.
- In-line ventilatorsysteem met bocht van 90°.
- Vlakke horizontale uitloop van het rookkanaal.
- Flexibele installatie van de ventilatorkast van het systeem. De in-line mechanische ventilatie moet minimaal 21' lang zijn (lineaire ventilatielengte) vanaf de aansluiting met de haard en kan op tot 45' van de haard worden geïnstalleerd.
- Geen elektriciën voor de installatie vereist.
- Ingebouwde bediening van de mechanische ventilatie. Eén enkel apparaatje bedient zowel de haard als de mechanische ventilatie.

**ES** Entre los más sofisticados de la industria, el Sistema de Ventilación Mecánica de Ortal le permite instalar nuestras chimeneas en lugares en los que los sistemas de ventilación directa convencional no pueden.

La colocación de la chimenea ya no depende de la ruta de ventilación. Este sistema permite una mayor flexibilidad para ubicar el aparato dentro del edificio. EL Sistema de Ventilación Mecánica crea una atracción mecánica en los gases de combustión de escape, haciendo posibles rutas de ventilación verticales y horizontales más largas y permitiendo a arquitectos, diseñadores y constructores trabajar con facilidad.

Ventajas del Sistema de Ventilación Mecánica Ortal:

- Tubo de ventilación pequeño. Tubo de chimenea de 5" de diámetro (35CVS por Duravent).
- Oportunidad de ductos de ventilación más largos, de hasta 110 pies, dependiendo del modelo de chimenea.
- Se puede instalar hasta con seis codos de 90 grados en el ducto de ventilación.
- Puede terminar debajo del quemador, no exceder caída vertical de 6' desde la parte superior del quemador (arriba).
- Operación silenciosa.
- Sistema de ventilador en línea con curva de 90 grados.
- Ventilación mecánica de línea final con terminación horizontal recta.
- Instalación flexible de la caja de soplador de Ventilación Mecánica. La ventilación mecánica en línea necesita un mínimo de 21 pies (longitud de ventilación lineal) desde el punto de conexión del quemador y puede ser instalada hasta a 45 pies del quemador.
- La instalación no requiere electricista.
- Control de Ventilación Mecánica Integrado. El mismo dispositivo controla el quemador y la Ventilación Mecánica.

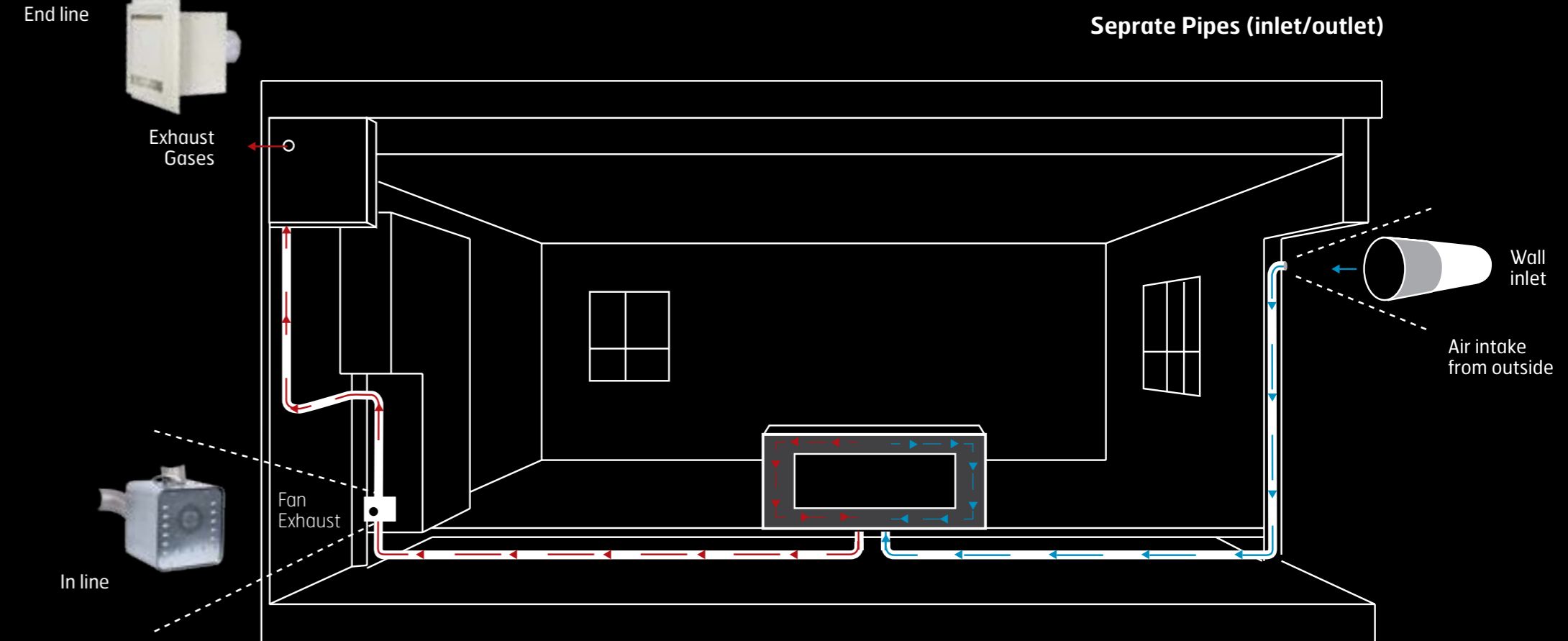

# BLOWER EXTENDING HEAT'S REACH

**EN** Maximize your fireplace's heating power. Blowers extract, rewarm and then distribute heated air throughout the interior, including to adjacent rooms. It's ideal for keeping large spaces consistently heated and warm. currently available for clear 130 and clear 170.

**DE** Ventilatoren maximieren die Heizkraft Ihres Kamins, indem sie die erwärmte Luft aus der Feuerstelle absaugen und sie noch weiter aufheizen, bevor sie die Luft wieder ausstoßen. Die Ventilationsssysteme können so eingerichtet werden, dass sie die aufgeheizte Luft in angrenzende Räume abgeben, wodurch die Wärmeverteilung Ihres Kamins gesteigert wird.

**NL** Blazers maximaliseren het verwarmingsvermogen van uw haard door hete lucht uit de haard aan te zuigen, ze nog verder te verwarmen en dan uit te stoten. Blazers kunnen worden geconfigureerd om warme lucht in aangrenzende kamers uit te stoten, zodat ze het verwarmingsbereik van uw haard vergroten.

**ES** Maximizando la potencia de calefacción de sus chimeneas, los sopladores funcionan extrayendo el aire calentado de la chimenea y calentándolo aún más antes de expulsarlo. Los sopladores pueden ser configurados para expulsar aire calentado hacia espacios adyacentes, extendiendo el alcance de calefacción de su chimenea.

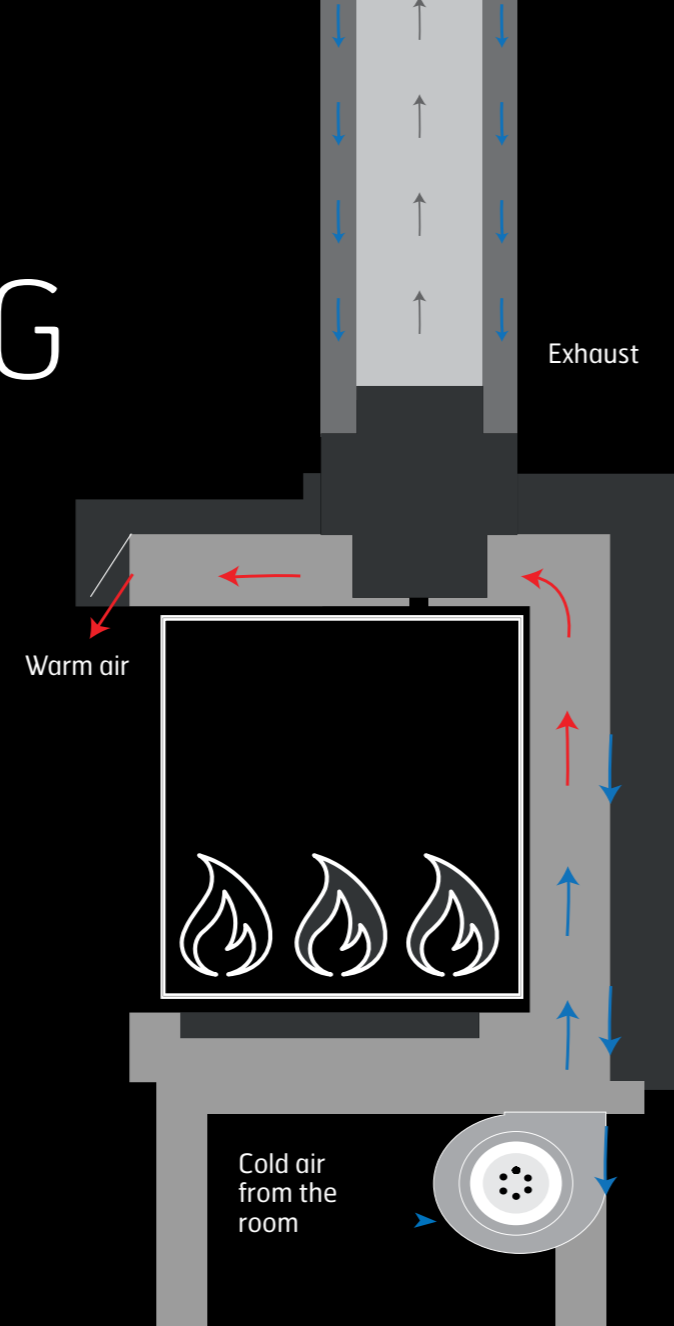



# LIGHTING ELEMENTS

**EN** With internal lighting, you'll be able to extend your fireplace's appeal regardless if its in use. Built-in, recessed lighting are controlled with your remote, adding ambiance all of the time.

**DE** Mithilfe einer Innenbeleuchtung können sie den Charme ihres Kamins steigern, unabhängig davon, ob er im Einsatz ist. Eingebaute Beleuchtung, die Sie mit Ihrer Fernbedienung steuern können, bietet Ihnen zu jeder Zeit zusätzliches Ambiente.

**NL** Een interne verlichting maakt uw haard nog aantrekkelijker, zelfs wanneer hij niet brandt. U regelt de ingebouwde, ingelaten elementen met uw afstandsbediening, voor extra sfeer.

**ES** Con iluminación interna, podrá aumentar el atractivo de su chimenea sin importar si está o no en uso. La iluminación empotrada integrada es controlada con su mando a distancia, añadiendo ambientación todo el tiempo.





## HEAT BARRIER SOLUTIONS IDEAL FOR COMMERCIAL SPACES

**EN** Ortal's Double Glass and Screen solutions ensure that the temperature on a fireplace's outer glass layer is significantly reduced and safe to the touch. Ideal for high-traffic public venues such as hotels, restaurants or commercial spaces, both solutions create an innovative barrier that reduces the temperature of the fireplace's glass enclosure without impacting design. Supporting any type of fireplace, including front-facing, tunnel (see-thru) and multisided models, you'll have uncompromising safety and aesthetics.

**DE** Die Konzepte für Doppelverglasung und Sichtscheiben von Ortal gewährleisten, dass die Temperatur der äußeren Scheibe des Kamins so deutlich gesenkt wird, dass man sie gefahrlos berühren kann. Das ist besonders ideal an Orten mit viel Publikumsverkehr, wie Hotels, Restaurants und in Geschäftsräumlichkeiten. Beide Lösungen schaffen eine innovative Barriere und reduzieren die Temperatur des Kaminglases, ohne sich negativ auf das Design auszuwirken. Passend für alle Kamintypen, Front-, Durchsicht- und Panoramakamine und kompromisslos in Sachen Sicherheit und Ästhetik.

**NL** De oplossingen van Ortal met dubbel glas of scherm verlagen de temperatuur van het glas aan de buitenkant van de haard zo efficiënt dat het veilig kan worden aangeraakt. Beide oplossingen zijn ideaal voor openbare gelegenheden met veel verkeer, zoals hotels, restaurants of winkelruimten. Ze scheppen een innovatieve barrière die de temperatuur van het glasomhulsel verlaagt zonder het design te beïnvloeden. Deze oplossingen voor een compromisloze veiligheid en esthetiek zijn geschikt voor alle soorten haarden, van frontale tot tunnelhaarden en meerzijdige modellen.

**ES** Las soluciones de Vidrio Doble y Pantalla de Ortal aseguran que la temperatura en la capa de vidrio externa de una chimenea se reduzca de manera importante y sea segura al tacto. Ideal para sitios con alto tráfico de público, tales como hoteles, restaurantes o espacios comerciales, ambas soluciones crean una innovadora barrera que reduce la temperatura de la caja de vidrio de la chimenea sin afectar el diseño. Compatible con cualquier tipo de chimenea, incluyendo modelos frontales, de túnel y de varios lados, tendrá usted seguridad y estética absolutas.



Patent-pending  
technology  
(USSN 60/040,074)



Double Glass



Protection Net

# WIDE FRAME FOR ELEGANT LOOK

**EN** Enhance the look of your fireplace by extending its view. With the Wide Frame design, the seamless glass enclosure extends beyond standard parameters for more impact.

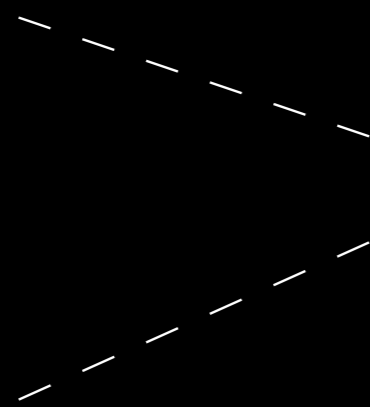

# "OPEN" FIRES

**EN** Create the illusion of open fireplace with the Double Break. A special transparent glass divider is set back within the fireplace, allowing for the placement of decorative rocks or logs in front, giving the look of an open fireplace, with the safety of an enclosure.



# OPERATION CONTROL OPTIONS

## New myfire© App

Ortal fireplaces include a remote control device that operates the pilot ignition, timer and thermostat as well as other optional features. Wall control units are also available, which can also be integrated into a smart house system.

In addition you can also Control your Ortal fireplace with the Symax© System from anywhere with the myfire© App. Using your Apple, Android smartphone or tablet, you'll get total control over features such as Eco Mode, Program Mode, Thermostatic Mode, Fan, Light, and Countdown Timer – from wherever you are. Able to control up to eight fireplaces, the myfire© App is known for its reliable performance and advanced technology.

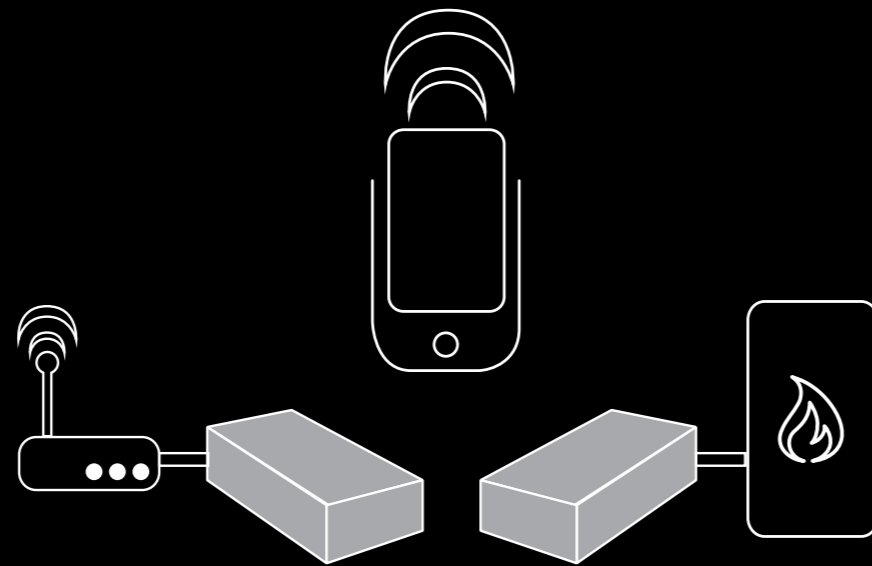

**MERTIK MAXITROL**



# LARGE FIREPLACES AS STANDARD

**EN** Ortal Modular Fireplaces can be seamlessly connected to create extended sizes and shapes affordably. You'll be able to create a custom fireplace, without the cost of customization.



# DUAL-LINE BURNER



**EN** Ortal's dual line burner features two lines that can be controlled separately, ensuring the best visual effect and avoiding overheating. It is the only fire in the market that covers the full length of the fireplace even when working at a lower setting. When the two line burners are operated at full capacity, the room will be quickly heated. In warmer days the visual effect of the fire is preserved by operating just one line alongside the full length of the fireplace. The dual line burner is available in all models except clear 40 models.

**DE** Ortals Dual-Line-Brenner verfügt über zwei Linien, die separat angesteuert werden können, für eine bestmögliche visuelle Wirkung und zur Vermeidung von Überhitzung. Es ist das einzige Feuer auf dem Markt, die die gesamte Länge des Kamins abdeckt auch bei Arbeiten auf einer niedrigeren Einstellung. Wenn die beiden Line-Brenner mit voller Kapazität betrieben werden, wird der Raum schnell erwärmt. An wärmeren Tagen wird die visuelle Wirkung des Feuers durch Betätigen einer einzigen Zeile auf der vollen Länge des Kamins erhalten. Der Dual-Line-Brenner ist in allen Modellen außer den clear 40 Modellen erhältlich.

**NL** De haard van Ortal met dubbele brander is voorzien van twee rijen die afzonderlijk regelbaar zijn, voor een prachtig visueel effect zorgen en oververhitting voorkomen. Het is de enige haard in de markt die over de volle lengte van de haard brandt, ook als de haard laag is ingesteld. Wanneer de twee rijen branders op volle capaciteit zijn ingesteld, zal de kamer snel warm worden. Op warmere dagen blijft het visuele effect van de haard bewaard door slechts één rij over de gehele lengte van de open haard aan te doen. Haarden met dubbele brander zijn verkrijgbaar in alle modellen behalve bij de clear 40 modellen.

**ES** Con iluminación interna, podrá aumentar el atractivo de su chimenea sin importar si está o no en uso. La iluminación empotrada integrada es controlada con su mando a distancia, añadiendo ambientación todo el tiempo.

# OVER 70 MODELS

**EN** Ortal welcomes your clients' vision for custom- designed made Fireplaces responding to special requirements, sizes and uses.

For technical specifications and more information, visit our website: [www.ortalheat.com](http://www.ortalheat.com)

\*please visit our website for technical drawings

**DE** Ortal nimmt gerne die Vorstellungen ihrer Kunden für selbst entworfene Kamine entgegen und geht dabei auf spezielle Anforderungen und Größen Nutzungsbedingungen ein.

Besuchen Sie unsere Webseite für technische Spezifikationen und weitere Infos: [www.ortalheat.com](http://www.ortalheat.com)

\*bitte besuchen Sie unsere Webseite für technische Zeichnungen

**NL** Ortal staat open voor de wensen van uw klanten voor open haarden op maat van bijzondere eisen in termen van afmetingen en toepassingen.

Raadpleeg voor technische specificaties en meer informatie onze website: [www.ortalheat.com](http://www.ortalheat.com)

\* bezoek onze website voor technische tekeningen

**ES** Ortal da la bienvenida a la visión de sus clientes para Chimeneas diseñadas a medida respondiendo a requerimientos, tamaños y usos especiales.

Para especificaciones técnicas y más información, visite nuestro sitio web: [www.ortalheat.com](http://www.ortalheat.com)

\*Visite nuestro sitio web para los dibujos técnicos

FRONT FACING 

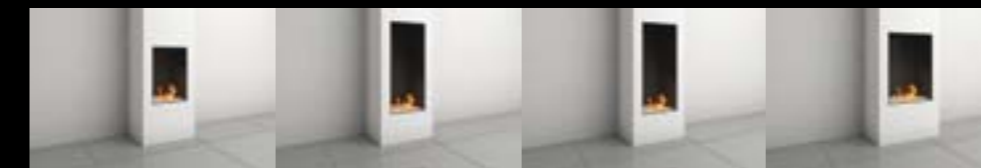

Clear 40      Clear 40H90      Clear 40H70      Clear 60X80



Clear 75X65      Clear 75      Clear 75X65 TR      Clear 110



Clear 110H      Clear 130      Clear 150      Clear 150H



Clear 170      Clear 200      Clear 200H      Clear 250



Minimal 110      Minimal 130

CORNER 

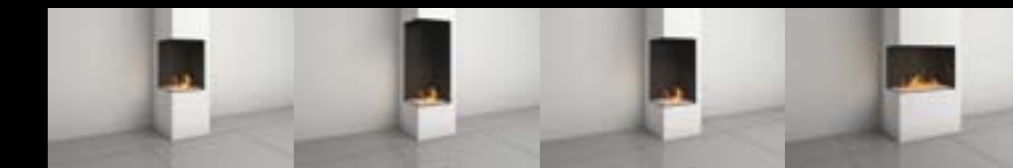

Clear 40 RS/LS      Clear 40H90 RS/LS      Clear 40H70 RS / LS      Clear 75RS / LS



Clear 110 RS / LS      Clear 130 RS / LS      Clear 150 RS / LS      Clear 170 RS / LS



Clear 200 RS / LS      Clear 250 RS / LS

# OVER 70 MODELS

## THREE SIDE

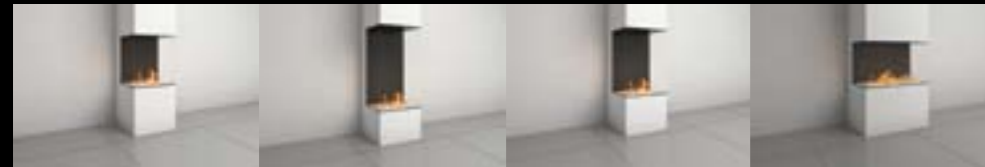

Clear 40 TS    Clear 40H90 TS    Clear 40H70 TS    Clear 75 TS



clear 75 H    Clear 110 TS    Clear 130 TS    Clear 150 TS



Clear 170 TS    Clear 200 TS    Clear 250 TS

## TUNNEL



Tunnel 40    Tunnel 40H90    Tunnel 40H70    Tunnel 60X80



Tunnel 75X65    Tunnel 110    Tunnel 110H    Tunnel 130



Tunnel 150    Tunnel 150H    Tunnel 170    Tunnel 200



Tunnel 200H    Tunnel 250

## SPACE CREATOR



Space Creator 75    Space Creator 120    Space Creator 120 mini    Space Creator 120 midi



Space Creator 150    Space Creator 200

## CIRCLE & ISLAND



Circle 70    Island 75    Island 130    Island 130 Hood



Circle 270

## STAND ALONE



Stand Alone 75    Stand Alone 110    Stand Alone 150    Classic Modern

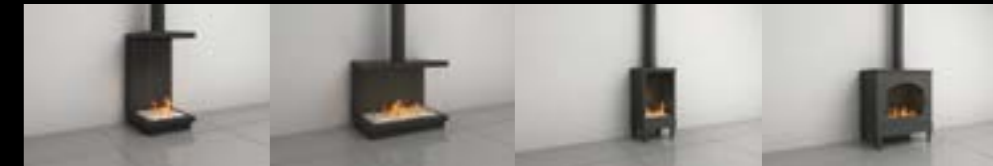

Stand Alone 40TS    Stand Alone 75TS    Small Square    Classic F 70

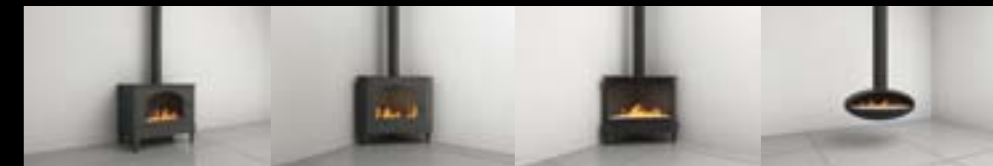

Classic F 80    Classic Corner    Modern Corner    Oval

\*please visit our website for technical drawings



